



EDM Supplies, Inc.®

Electrodes • Tooling • Accessories

800-676-7336 • Fax 562-803-4281

www.edmsupply.com • E-mail info@edmsupply.com

EDM WIRES

TABLE OF CONTENTS

	Page
Specifications	2
Cobra Cut	4
Cobra Cut A	5
Cobra Cut B	6
Cobra Cut D	7
Cobra Cut S	8
Cobra Cut W	8
Topas Plus Hard	9
Topas Plus Soft	10
Topas Plus X	11
Bronco Cut X	12
MegaCut A	13
MegaCut D	14
MegaCut T	14
Berco Cut 400 Brass	15
Berco Cut 500 Brass	16
Berco Cut 900 Hard Brass	17
Berco Cut Special	18
Berco Cut Pro 900	19
MicroCut Wire	20
Gamma Phase Wire	22
PremiumCut Zinc Coated Wire	23
PremiumCut Brass Wire	24
Molybdenum Spooled Wire	25
Copper Spooled Wire	26



EDM Supplies, Inc.®

Electrodes • Tooling • Accessories

800-676-7336 • Fax 562-803-4281

www.edmsupply.com • E-mail info@edmsupply.com

SPECIFICATIONS - TECHNICAL DATA

SPOOL SIZES

Lbs.	Kgs.	Type	A	B	C
3.5	1.6	DIN 100	4"	4"	5/8"(16mm)
8	3.5	DIN 125	5"	5"	5/8"(16mm)
13.5	6	DIN 160	6"	6"	7/8"(22mm)
17.5	8	DIN 160	6"	6"	7/8"(22mm)
35	15.7	DIN 200	8"	8"	7/8"(22mm)
6.6	3	P 3	4-1/3"	5-1/8"	4/5"(20mm)
11	5	P 5	4-1/2"	6-1/3"	4/5"(20mm)
22	10	P10	5-1/4"	7-3/4"	63/64"(25mm)
44	20	P 15	5-1/2"	9-3/4"	1-3/4"(31mm)

DIN = German Technical standard

P = Japanese standard

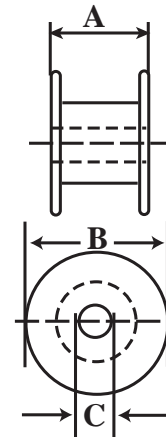

*P15 Bronco Cut X is 55 lb.

Lbs	Kgs	Type	a	b	c	d	e
88	4	Bedra 4	5.1"	3.1"	.9'	4.1"	4.9'
17.5	8	Bedra 8	3.9'	3.9'	.9'	5.3'	6.3'
35	16	Bedra 16	.9'	4.9'	.9'	6.5'	7.9'

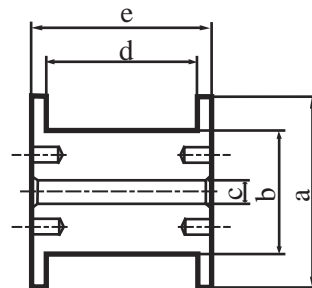
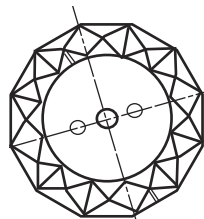



EDM Supplies, Inc.®

Electrodes • Tooling • Accessories

800-676-7336 • Fax 562-803-4281

www.edmsupply.com • E-mail info@edmsupply.com

SPECIFICATIONS - TECHNICAL DATA PHYSICAL PROPERTIES OF BEDRA EDM WIRES

Type	Density - gm/cc	Melting Point C	Conductivity	Tensile
CobraCut	8.4	900 - 920	21%	70,000 PSI
CobraCut A	8.4	900 - 920	20%	130,000 PSI
CobraCut B	8.9	950 - 1060	62%	65,000 PSI
CobraCut D	8.7	970 - 1000	29%	115,000 PSI
CobraCut S	8.7	970 - 1000	29%	115,000 PSI
Topas Plus Soft	8.4	900-920	20%	70,000 PSI
Topas Plus Hard	8.4	900-920	20%	115,000 PSI
Topax Plus X	8.9	1083	77%	72,000 PSI
BroncoCut X	8.9	1083	77%	72,000 PSI
MegaCut A	8.4	900 - 920	20%	130,000 PSI
MegaCut D	8.7	970 - 1000	29%	115,000 PSI
MegaCut T	8.4	900 - 920	21%	70,000 PSI
BercoCut 400 Extra Soft Brass	8.4	900 - 920	20%	55,000 PSI
BercoCut 500 Soft Brass	8.4	900 - 920	20%	71,000 PSI
BercoCut 900 Hard Brass	8.4	900 - 920	20%	130,000 PSI
BercoCut Pro 900 Hard Brass	8.4	900-920	20%	133,000 PSI

Wire Dia.		spool weight lbs.						
Inch	MM	3.5	6.6	8	11	13.5	35	44
.002"	0.05	103,250	N/A	N/A	N/A	N/A	N/A	N/A
.003"	0.07	45,500	N/A	N/A	N/A	N/A	N/A	N/A
.004"	0.10	25,800	N/A	N/A	N/A	N/A	N/A	N/A
.006"	0.15	11,500	22,000	25,000	36,300	42,600	N/A	N/A
.008"	0.20	6,600	12,300	13,700	20,600	24,000	62,800	81,400
.010"	0.25	4,050	7,800	8,700	13,000	15,300	40,400	52,800
.012"	0.30	2,800	5,400	6,000	9,000	10,900	28,200	35,200
.013"	0.33	2,250	4,250	5,150	7,100	8,700	21,300	28,400



EDM Supplies, Inc.®

Electrodes • Tooling • Accessories

800-676-7336 • Fax 562-803-4281

www.edmsupply.com • E-mail info@edmsupply.com

COBRA CUT

These zinc-coated wire electrodes were initially produced for AGIE for their first AC machines. Due to its elongation, it is particularly suitable for high tapering. It has a limited suitability for machine models with automatic water-jet threading.

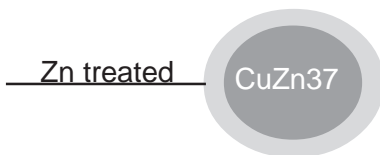

Elongation:
15%
Color: light grey

8.8 lb. spool

Box Quantity: 4

Crate Quantity: 32

DIA	CATALOG NO.
.008	C02-0888
.010	C02-1088

17.5 lb. spool (Bedra 8)

Box Quantity: 2

Crate Quantity: 24

DIA	CATALOG NO.
.010	C02-10175
.012	C02-12175

35 lb. spool

Box Quantity: 1

Crate Quantity: 18

DIA	CATALOG NO.
.008	C02-0830
.010	C02-1030
.012	C02-1230

Please call for price and availability



EDM Supplies, Inc.®

Electrodes • Tooling • Accessories

800-676-7336 • Fax 562-803-4281

www.edmsupply.com • E-mail info@edmsupply.com

COBRA CUT A

Hard Brass Core/Tensile Strength 130,000 PSI

This hard, zinc-coated wire electrode is especially suitable for machines with automatic threaders. Due to its excellent straightness and precision, it guarantees very good surface qualities and allows precision cuts and fine detail with the highest reliability in automatic operations (particularly with .003", .004" and .006" diameter wires).

With this wire, steep taper cuts are possible only to a limited extent, except on the following AGIE machines models for which it is specified: AC 100, 200, 300, 100D, 200D and 300D.

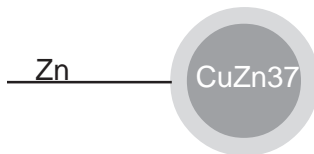

Elongation: 1%

Color: bright silver

8.8 lb. spool Bedra 4

Box Quantity: 4 Crate Quantity: 32

DIA	CATALOG NO.
.010	C02-0688A
.012	C02-1288A

17.5 lb. spool (Bedra 8)

Box Quantity: 2 Crate Quantity: 24

DIA	CATALOG NO.
.006	C02-06175D
.008	C02-08175D
.010	C02-01075D
.012	C02-12175D

35 lb. spool

Box Quantity: 1 Crate Quantity: 18

DIA	CATALOG NO.
.008	C02-0830A
.010	C02-1030A
.012	C02-1230A
.013	C02-1330A

55 lb. spool

Box Quantity: 4 Crate Quantity: 32

DIA	CATALOG NO.
.010	C02-1055A
.012	C02-1255A

Please call for price and availability



EDM Supplies, Inc.®

Electrodes • Tooling • Accessories

800-676-7336 • Fax 562-803-4281

www.edmsupply.com • E-mail info@edmsupply.com

COBRA CUT B

Type: **Soft/Tensile Strength 65,000 PSI**

The special CuMg core of this electrode provides high electrical conductivity. Its rougher, oxidized surface benefits flushing conditions and is advantageous for the cutting of tall work pieces (>4"). Recommended for fast cutting of graphite and aluminum alloys.

This wire is suitable for tapering to 20°, but has limited capability for skim cutting and automatic wire threading. It is specified for the following AGIE models: AC 100, 200, 300, 100D, 200D and 300D.

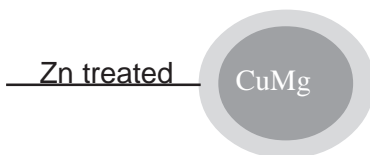

Elongation: 3%
Color: grey

7.7 lb. spool

Box Quantity: 4 Crate Quantity: 32

DIA	CATALOG NO.
.010	C02-1077B
.012	C02-1277B

11 lb. spool

Box Quantity: 4 Crate Quantity: 32

DIA	CATALOG NO.
.010	C02-1011B
.012	C02-1211B

35 lb. spool

Box Quantity: 1 Crate Quantity: 18

DIA	CATALOG NO.
.008	C02-0830B
.010	C02-1030B
.012	C02-1230B

Please call for price and availability



EDM Supplies, Inc.®

Electrodes • Tooling • Accessories

800-676-7336 • Fax 562-803-4281

www.edmsupply.com • E-mail info@edmsupply.com

COBRA CUT D

Type: 1/2 Hard/Tensile Strength 115,000 PSI

This wire electrode has been developed for EDM machines with high-power generators. It has a high thermal and electrical conductivity due to its special coating. It consists of two CuZn alloys (brass-on-brass), and is therefore suitable for speed cutting as well as for precision contour cutting.

It can be used on machines with automatic threading. Tapered cuts (>7°) are possible only to a limited extent, except on the following AGIE machine models for which this wire is specified: AC 100D, 200D, and 300D.

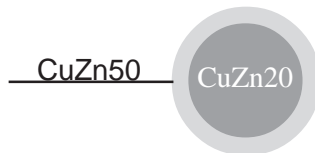

Elongation: 1%
Color: yellow brown

8.8 lb. spool

Box Quantity: 4

Crate Quantity: 32

DIA	CATALOG NO.
.010	C0T-1088X
.012	C0T-1288X

17.5 lb. spool (Bedra 8)

Box Quantity: 2

Crate Quantity: 24

DIA	CATALOG NO.
.006	C02-06175D
.008	C02-08175D
.010	C02-01075D
.012	C02-12175D

35 lb. spool

Box Quantity: 1

Crate Quantity: 18

DIA	CATALOG NO.
.008	C02-0835D
.010	C02-1035D
.012	C02-1235D
.013	C02-1335D

Please call for price and availability



EDM Supplies, Inc.®

Electrodes • Tooling • Accessories

800-676-7336 • Fax 562-803-4281

www.edmsupply.com • E-mail info@edmsupply.com

COBRA CUT S

Type: 1/2 Hard/Hard Brass Core/Tensile strength 115,000 PSI

This wire electrode guarantees highest cutting rates on the latest high-power EDM machines. As an improvement of the COBRA CUT Type D, the thicker diffusion coat provides better cutting performance. It is most suitable for use in high-volume production EDM, tool and die making, and for thick workpieces.

It is suitable for automatic threading and is specified for AGIE AC Sprint machines.

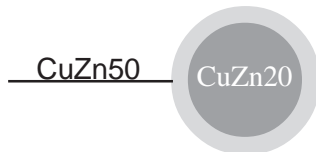

Elongation: 1%
Color: yellow-brown

35 lb. spool

Box Quantity: 1 Crate Quantity: 18

DIA	CATALOG NO.
.012	C02-1235S
.013	C02-1335S

COBRA CUT W

Type: Soft/Tensile strength 62,700 PSI

This diffusion-annealed wire is designed to deliver the high productivity of Cobra Cut D with the high elongation of BercoCut 390 wire. Suitable to taper cuts up to 45°.

17.5 lb. spool (Bedra 8)

Box Quantity: 2 Crate Quantity: 24

DIA	CATALOG NO.
.010	C02-10175W

35 lb spool

Box Quantity: 1 Crate Quantity: 18

DIA	CATALOG NO.
.010	C02-1035W

Please call for price and availability



EDM Supplies, Inc.®

Electrodes • Tooling • Accessories

800-676-7336 • Fax 562-803-4281

www.edmsupply.com • E-mail info@edmsupply.com

Topas Plus Hard

Type: Hard/Tensile strength 115,000 PSI

With its high tensile strength, Topas Plus Hard is particularly suited for machines which require straightened wires for threading. A crucial advantage is the universal usability of the TOPAS EDM wires on all conventional EDM machines with existing standard technologies. This allows considerable performance advantages without involving extra time and costs for reprogramming.

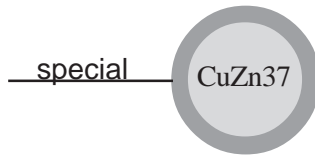

Elongation: 1%
Color: grey-gold

11 lb. spool

Box Quantity: 4 Crate Quantity: 32

DIA	CATALOG NO.
.010"	COT-1011HP
.012"	COT-1211HP

17.5 lb. spool (Bedra 8)

Box Quantity: 2 Crate Quantity: 24

DIA	CATALOG NO.
.010"	COT-10175HP
.012"	COT-12175HP

22 lb. spool

Box Quantity: 2 Crate Quantity: 24

DIA	CATALOG NO.
.010"	COT-1022HP
.012"	COT-1222HP

35 lb. spool

Box Quantity: 1 Crate Quantity: 18

DIA	CATALOG NO.
.010"	COT-1035HP
.012"	COT-1235HP

44 lb. spool

Box Quantity: 1 Crate Quantity: 16

DIA	CATALOG NO.
.010"	COT-1044HP
.012"	COT-1244HP

Please call for price and availability



EDM Supplies, Inc.®

Electrodes • Tooling • Accessories

800-676-7336 • Fax 562-803-4281

www.edmsupply.com • E-mail info@edmsupply.com

TOPAS Plus Soft

Type: Soft/Tensile strength 70,000 PSI

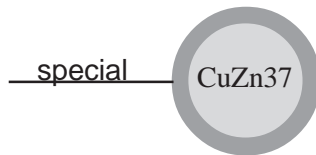

Elongation: 1%
Color: grey-gold

TOPAS S is especially suited for taper cutting with reliable edge-finding.

8.8 lb. spool

Box Quantity: 4 Crate Quantity: 32

DIA	CATALOG NO.
.010"	C0T-1088SP
.012"	C0T-1288SP

11 lb. spool

Box Quantity: 4 Crate Quantity: 32

DIA	CATALOG NO.
.010"	C0T-1011SP
.012"	C0T-1211SP

17.5 lb. spool

Box Quantity: 2 Crate Quantity: 24

DIA	CATALOG NO.
.010"	C0T-10175SP
.012"	C0T-12175SP

35 lb. spool

Box Quantity: 1 Crate Quantity: 18

DIA	CATALOG NO.
.010"	C0T-1035SP
.012"	C0T-1235SP

Please call for price and availability



EDM Supplies, Inc.®

Electrodes • Tooling • Accessories

800-676-7336 • Fax 562-803-4281

www.edmsupply.com • E-mail info@edmsupply.com

TOPAS PLUS X

Type: Soft/Tensile Strength 72,000 PSI

New gamma phase wire with high precision and up to 35% higher cutting speed as compared to brass wire. Developed especially for the X technology on Charmilles machines. Can be used immediately without modifying machine settings.

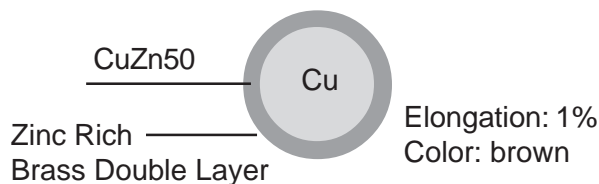

8.8 lb. spool

Box Quantity: 4 Crate Quantity: 32

DIA.	CATALOG NO.
.010	C0T-1088X
.012	C0T-1288X

11 lb. spool

Box Quantity: 4 Crate Quantity: 32

DIA.	CATALOG NO.
.010"	C0T-1011X
.012"	C0T-1211X

17.6 lb. spool

Box Quantity: 2 Crate Quantity: 18

DIA.	CATALOG NO.
.010"	C0T-10175X
.012"	C0T-12175X

38.2 lb. spool

Box Quantity: 1 Crate Quantity: 1

DIA.	CATALOG NO.
.010"	C0T-1035X
.012"	C0T-1235X

Please call for price and availability



EDM Supplies, Inc.®

Electrodes • Tooling • Accessories

800-676-7336 • Fax 562-803-4281

www.edmsupply.com • E-mail info@edmsupply.com

BRONCO CUT X

Type: Soft/Tensile Strength 72,000 PSI

This high-performance, multipurpose EDM wire with a special zinc-rich coating, is suitable for precision cutting as well as high-speed cutting. Excellent automatic threading reliability except for the following Charmilles machines Robofil 100 and 1000 series. Taper cutting (>7°) only to a limited degree.

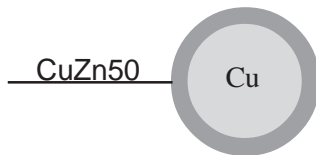

Elongation: 1%
Color: brown

6.6 lb. spool

Box Quantity: 4 Crate Quantity: 32

DIA	CATALOG NO.
.008	C09-0866BX
.010	C09-1066BX
.012	C09-1266BX

8.8 lb. spool

Box Quantity: 4 Crate Quantity: 32

DIA	CATALOG NO.
.010	C09-1088BX

11 lb. spool

Box Quantity: 4 Crate Quantity: 32

DIA	CATALOG NO.
.010	C09-1011BX
.012	C09-1211BX

17.5 lb. spool (Bedra 8)

Box Quantity: 2 Crate Quantity: 24

DIA	CATALOG NO.
.010	C09-10175B
.012	C09-12175B

35 lb. spool

Box Quantity: 1 Crate Quantity: 18

DIA	CATALOG NO.
.010	C09-1035BX
.012	C09-1235BX

55 lb. spool

Box Quantity: 1 Crate Quantity: see below

DIA	CATALOG NO.
.010	C09-1055BX
.012	C09-1255BX

Available on both P15 and DIN 250 spools
Crate quantity for P15 spool is 16
Crate quantity for DIN 250 spool is 12

Please call for price and availability



EDM Supplies, Inc.®

Electrodes • Tooling • Accessories

800-676-7336 • Fax 562-803-4281

www.edmsupply.com • E-mail info@edmsupply.com

MEGACUT A

Type: Hard/Tensile Strength 130,000 PSI

In small diameters (.003" - .008"), this zinc-coated precision wire is suitable for cuts with tight corner radii. It offers high cutting rates and performs well in critical applications (for example, in tungsten carbide alloys). The wire has excellent manual and automatic threading capabilities. Taper cutting (>7°) is only possible to a limited degree. This wire is in compliance with Mitsubishi EDMs.

This wire is used when fine surfaces are required, it is also recommended when cutting carbides and poly-crystalline diamond.

Zn treated

CuZn37

Elongation: 1%

Color: light grey

11 lb. spool

Box Quantity: 4

Crate Quantity: 32

DIA	CATALOG NO.
.006	C02-0611A
.008	C02-0811A
.010	C02-1011A
.012	C02-1211A

22 lb. spool

Box Quantity: 2

Crate Quantity: 24

DIA	CATALOG NO.
.010	C02-1022A
.012	C02-1222A

44 lb. spool

Box Quantity: 1

Crate Quantity: 16

DIA	CATALOG NO.
.010	C02-1044A
.012	C02-1244A

Please call for price and availability



EDM Supplies, Inc.®

Electrodes • Tooling • Accessories

800-676-7336 • Fax 562-803-4281

www.edmsupply.com • E-mail info@edmsupply.com

MEGACUT D

Due to its special coating, this electrode is ideal for speed cutting, providing the highest performance. This wire is also recommended for tall workpieces, interrupted cuts and poor flushing conditions. For taper cutting (>7°), this wire is suitable only to a limited extent. Type D wire complies with Mitsubishi EDMs.

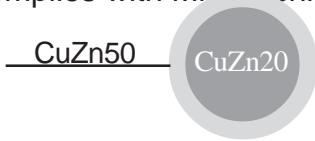

Elongation: 1%
Color: yellow-brown

6.6 lb. spool

Box Quantity: 4 Crate Quantity: 32

DIA	CATALOG NO.
.006	C02-0666D
.008	C02-0866D
.010	C02-1066D
.012	C02-1266D

11 lb. spool

Box Quantity: 4 Crate Quantity: 32

DIA	CATALOG NO.
.006	C02-0611D
.008	C02-0811D
.010	C02-1011D
.012	C02-1211D
.013	C02-1311D

44 lb. spool

Box Quantity: 1 Crate Quantity: 16

DIA	CATALOG NO.
.010	C02-1044D
.012	C02-1244D

MEGACUT T

Type: Soft/70,000 PSI

This wire electrode is similar to MEGACUT Type A but has reduced hardness, making it perfectly suitable for high tapering requirements. Because of this increased tapering capability, this wire will have limited automatic threading capability. It is a soft zinc coated brass wire for machines with round diamond guides.

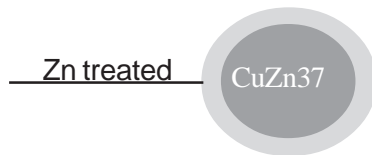

Elongation: 15%
Color: light grey

6.6 lb. spool

Box Quantity: 4 Crate Quantity: 32

DIA	CATALOG NO.
.006	C02-0666T
.008	C02-0866T
.010	C02-1066T

11 lb. spool

Box Quantity: 4 Crate Quantity: 32

DIA	CATALOG NO.
.008	C02-0811T
.010	C02-1011T
.012	C02-1211T

Please call for price and availability



EDM Supplies, Inc.®

Electrodes • Tooling • Accessories

800-676-7336 • Fax 562-803-4281

www.edmsupply.com • E-mail info@edmsupply.com

BERCO CUT 400 BRASS

Tensile Strength: 55,000 PSI

Softest brass available. It has a high elongation and is suitable for taper cuts greater than 20°. It is recommended as a replacement for the Stamm wire specified by Charmilles for use on 300/310 and 500/510 series.

CuZn37

8.8 lb. spool

Box Quantity: 4

Crate Quantity: 32

DIA.	CATALOG NO.
0.01	C01-1088BS

17.5 lb. spool (Bedra 8)

Box Quantity: 2

Crate Quantity: 24

DIA.	CATALOG NO.
.010"	C01-10175S
.012"	C01-12175S

Please call for price and availability



EDM Supplies, Inc.®

Electrodes • Tooling • Accessories

800-676-7336 • Fax 562-803-4281

www.edmsupply.com • E-mail info@edmsupply.com

BERCO CUT 500 BRASS

Tensile Strength: 71,000 PSI

Like the coated products, plain brass EDM wires are subject to strict production standards. For the EDM user, this guarantees reliable and uniform cutting results on EDMs from all manufacturers. CuZn37 (Ms63) is available as plain brass with a tensile strength of 70,000 PSI.

CuZn37

3.5 lb. spool

Box Quantity: 8 Crate Quantity: 72

DIA	CATALOG NO.
.010"	C01-1033
.012"	C01-1233

8.8 lb. spool

Box Quantity: 4 Crate Quantity: 32

DIA	CATALOG NO.
.010"	C01-1088
.012"	C01-1288

6.6 lb. spool

Box Quantity: 4 Crate Quantity: 32

DIA	CATALOG NO.
.010"	C01-1066

11 lb. spool

Box Quantity: 4 Crate Quantity: 32

DIA	CATALOG NO.
.010"	C01-1011
.012"	C01-1211

17.5 lb. spool

Box Quantity: 2 Crate Quantity: 24

DIA	CATALOG NO.
.010"	C01-10175
.012"	C01-12175

35 lb. spool

Box Quantity: 1 Crate Quantity: 18

DIA	CATALOG NO.
.010"	C01-1030
.012"	C01-1230

Please call for price and availability



EDM Supplies, Inc.®

Electrodes • Tooling • Accessories

800-676-7336 • Fax 562-803-4281

www.edmsupply.com • E-mail info@edmsupply.com

BERCO CUT 900 HARD BRASS

Tensile Strength: 130,000 PSI

The hard brass EDM wires are subject to the same strict production standards as the plain brass and coated wires. CuZn37 (Ms63) is available in a hard temper with a tensile strength of 130,000 PSI. Hard Brass wire is suitable for auto threading.



3.5 lb. spool

Box Quantity: 8 Crate Quantity: 72

DIA.	CATALOG NO.
.006	C01-0633HB
.008	C01-0833HB

8.8 lb. spool

Box Quantity: 4 Crate Quantity: 32

DIA.	CATALOG NO.
.010	C01-1088HB

13.5 lb. spool

Box Quantity: 2 Crate Quantity: 24

DIA.	CATALOG NO.
.010"	C01-10132H
.012"	C01-12132H

17.5 lb. spool

Box Quantity: 2 Crate Quantity: 24

DIA.	CATALOG NO.
.008	C01-08175H
.010	C01-10175H

35 lb. spool

Box Quantity: 1 Crate Quantity: 18

DIA.	CATALOG NO.
.008	C01-0830HB
.010	C01-1030HB
.012	C01-1230HB

55 lb. spool

Box Quantity: 1

DIA.	CATALOG NO.
.010	C01-1055H

Please call for price and availability



EDM Supplies, Inc.®

Electrodes • Tooling • Accessories

800-676-7336 • Fax 562-803-4281

www.edmsupply.com • E-mail info@edmsupply.com

BERCO CUT SPECIAL

For Japanese Machines

Type: Hard/Tensile Strength: 130,000 PSI

Berco Cut Special Brass EDM wires are subject to the same strict production standards as the other brass and coated wires. CuZn37 (Ms63) is available in a hard temper with a tensile strength of 130,000 PSI and is suitable for auto threading. Berco Cut Special brass is straightened specifically for use on Japanese machines. It is only available on Japanese standard spools.

6.6 lb. spool

Box Quantity: 4

Crate Quantity: 32

DIA	CATALOG NO.
.008	C01-0866HB
.010	C01-1066HB
.012	C01-1266HB

11 lb. spool

Box Quantity: 4

Crate Quantity: 32

DIA	CATALOG NO.
.006	C01-0611HB
.008	C01-0811HB
.010	C01-1011HB
.012	C01-1211HB

22 lb. spool

Box Quantity: 2

Crate Quantity: 24

DIA	CATALOG NO.
.010	C01-1022HB
.012	C01-1222HB

44 lb. spool

Box Quantity: 1

Crate Quantity: 16

DIA	CATALOG NO.
.008	C01-0844HB
.010	C01-1044HB
.012	C01-1244HB

Please call for price and availability



EDM Supplies, Inc.®

Electrodes • Tooling • Accessories

800-676-7336 • Fax 562-803-4281

www.edmsupply.com • E-mail info@edmsupply.com

BERCO CUT PRO 900

Type: Hard/Tensile Strength: 130,000 PSI

Paraffin free wire

Berco Cut Pro represents the latest development from Bedra in the segment of brass wire. Berco Cut Pro has a paraffin-free surface that guarantees reliable automatic threading and smooth unwinding on the Japanese machines which have automatic threaders.

11 lb. spool

Box Qty: 4 Crate Qty: 32

DIA	CATALOG NO.
.010	C01-1011MG
.012	C01-1211MG

22 lb. spool

Box Qty: 2 Crate Qty: 24

DIA	CATALOG NO.
.010	C01-1022MG
.012	C01-1211MG

44 lb. spool

Box Qty: 1 Crate Qty: 16

DIA	CATALOG NO.
.010	C01-1044MG
.012	C01-1244MG

Please call for price and availability



EDM Supplies, Inc.®

Electrodes • Tooling • Accessories

800-676-7336 • Fax 562-803-4281

www.edmsupply.com • E-mail info@edmsupply.com

MICROCUT®

Tensile Strength: 290,000 PSI

This EDM wire, especially developed for fine- and micro EDming is available in diameters down to 0.02mm. With a special zinc-rich brass coating over its high-strength steel core, it provides optimum process stability, the highest dimensional accuracy and superior surface finishes.

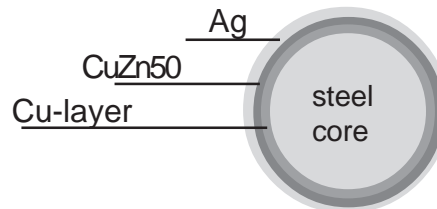

5000 Meter Spool

Box Quantity: 2 Crate Quantity: N/A

DIA	DIA	CATALOG NO.
0.03 mm	0.0012	C00-50012
0.05 mm	0.0020	C00-50020
0.06 mm	0.0024	C00-50024
0.07 mm	0.0028	C00-50028
0.08 mm	0.0032	C00-50032
0.10 mm	0.0040	C00-50040

Also available in 10,000 meter spools

Each spool is individually packed in a plastic can and several of these are placed in a styrofoam box. This practically eliminates any contamination or damage to the high tech wire.

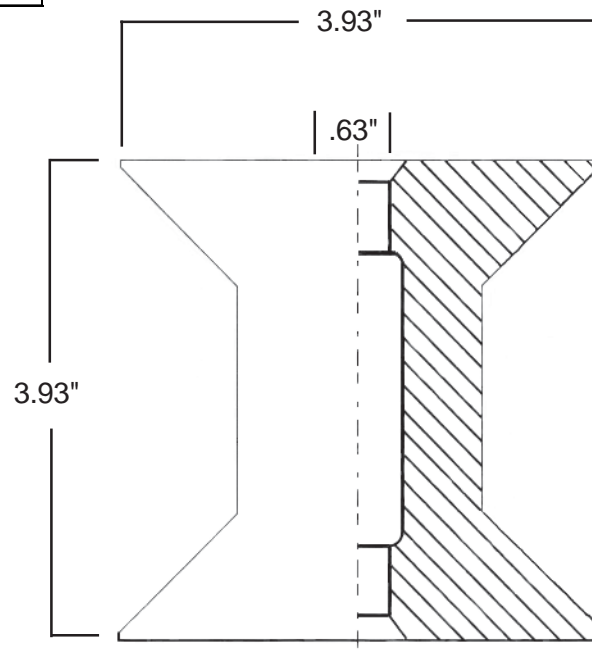

Please call for price and availability



EDM Supplies, Inc.®

Electrodes • Tooling • Accessories

800-676-7336 • Fax 562-803-4281

www.edmsupply.com • E-mail info@edmsupply.com

MICRO CUT

Small Diameter Wire

Bare Brass - Hard

Tensile Strength: 130,000 PSI

DIA	CATALOG NO.	SPOOL SIZE
.004	C01-20040	20,000M

4 Per Case

Zinc Coated Brass - Hard

Tensile Strength: 130,000 PSI

DIA	CATALOG NO.	SPOOL SIZE
.003	C02-20030	20,000M
.004	C02-20040	20,000M

4 Per Case

* 20,000 meters = approx 3.9 lbs of wire.

Type	a	b	c	d	e
Bedra 4	5.1"	3.1"	.9"	4.1"	4.9"

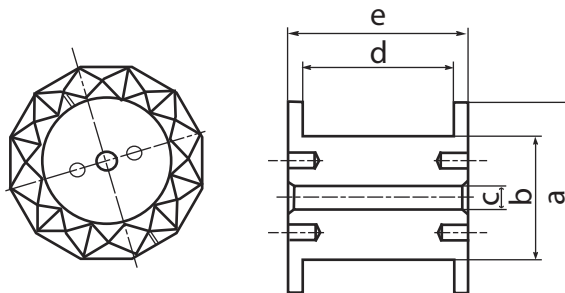

Please call for price and availability



EDM Supplies, Inc.®

Electrodes • Tooling • Accessories

800-676-7336 • Fax 562-803-4281

www.edmsupply.com • E-mail info@edmsupply.com

Gamma Phase Wires

GAMMA-BRASS

type: Gamma 65/35 hard

11 lb spool
Box Quantity: 4

DIA	CATALOG NO.
.008	GB-0811H
.010	GB-1011H
.012	GB-1211H

17.6 lb spool
Box Quantity: 2

DIA	CATALOG NO.
.010	GB-10176H
.012	GB-12176H

22 lb spool
Box Quantity: 2

DIA	CATALOG NO.
.010	GB-1022H
.012	GB-1222H

35.2 lb spool
Box Quantity: 1

DIA	CATALOG NO.
.010	GB-1035H
.012	GB-1235H

GAMMA-BRASS

type: Gamma 65/35 1/2 hard

7.7 lb Spool
Box Quantity: 4

DIA	CATALOG NO.
.010	GB-1077

Please call for price and availability



EDM Supplies, Inc.®

Electrodes • Tooling • Accessories

800-676-7336 • Fax 562-803-4281

www.edmsupply.com • E-mail info@edmsupply.com

PREMIUM CUT PRECISION ZINC COATED WIRE

Type: Hard

11 lb. spool

Box Qty: 4 Crate Qty: 108

DIA	CATALOG NO.
.008	C0P-0811DZ
.010	C0P-1011DZ
.012	C0P-1211DZ

Spool Size - P5

6-1/3" OD x 4-1/2" Wide x 20 mm ID

22 lb. spool

Box Qty: 1 Crate Qty: 40

DIA	CATALOG NO.
.010	C0P-1022DZ
.012	C0P-1222DZ

Spool Size - P10

7 3/4" OD x 5 1/4" wide x 25mm ID

35.2 lb. spool

Box Qty: 1 Crate Qty: 36

DIA	CATALOG NO.
.010	C0P-1035DZ
.012	C0P-1235DZ

Spool Size - DIN 200

44 lb. spool

Box Qty: 1 Crate Qty: 30

DIA	CATALOG NO.
.010	C0P-1044DZ
.012	C0P-1244DZ

Spool Size - P15

9-3/4" OD x 5-1/2" Wide x 31 mm ID

PHYSICAL PROPERTIES

Composition, Core	65/35
Coating	Zinc
Elongation, %	3
Tensile Strength, PSI	125,000
Diameter Tolerance, inches	+zero/-.00004

Please call for price and availability



EDM Supplies, Inc.®

Electrodes • Tooling • Accessories

800-676-7336 • Fax 562-803-4281

www.edmsupply.com • E-mail info@edmsupply.com

PREMIUMCUT® PRECISION BRASS WIRE - PARAFFIN FREE

Type: Hard

11 lb. spool

Box Quantity: 4 Crate Quantity: 108

DIA	CATALOG NO.
.008	C0P-0811HB
.010	C0P-1011HB
.012	C0P-1211HB

Spool Size - P5

6 1/3" OD x 4-1/28" Wide x 20mm ID

13.5 lb. spool

Box Quantity: 2 Crate Quantity: 108

DIA	CATALOG NO.
.008	C0P-08132H
.010	C0P-10132H
.012	C0P-12132H

Spool Size - P5

6 1/3" OD x 4-1/28" Wide x 20mm ID

22 lb. spool

Box Quantity: 1 Crate Quantity: 40

DIA	CATALOG NO.
.008	C0P-0822HB
.010	C0P-1022HB
.012	C0P-1222HB

Spool Size - P10

7-3/4" OD x 5-1/4" Wide x 25 mm ID

PHYSICAL PROPERTIES

Composition, Cu/Zn	60/40
Elongation, %	3
Tensile Strength, PSI	130,000
Diameter Tolerance, inches	+zero/-.00004

Please call for price and availability



EDM Supplies, Inc.®

Electrodes • Tooling • Accessories

800-676-7336 • Fax 562-803-4281

www.edmsupply.com • E-mail info@edmsupply.com

PREMIUMCUT® PRECISION BRASS WIRE - PARAFFIN FREE

Type: Hard

17.6 lb. spool

Box Qty: 2 Crate Qty: 40

DIA.	CATALOG NO.
.010	C0P-10175H

Spool Size - DIN 160

35.2 lb. spool

Box Qty: 1 Crate Qty: 36

DIA.	CATALOG NO.
.010	C0P-1035HB
.012	C0P-1235HB

Spool Size - DIN 200
8" OD x 8" Wide x 7/8" ID

44 lb. spool

Box Qty: 1 Crate Qty: 30

DIA.	CATALOG NO.
.008	C0P-0844HB
.010	C0P-1044HB
.012	C0P-1244HB

Spool Size - P15
9-3/4" OD x 5-1/2" Wide x 31 mm ID

PHYSICAL PROPERTIES

Composition, Cu/Zn	60/40
Elongation, %	3
Tensile Strength, PSI	130,000
Diameter Tolerance, inches	+zero/- .00004

Please call for price and availability



EDM Supplies, Inc.[®]

Electrodes • Tooling • Accessories

800-676-7336 • Fax 562-803-4281

www.edmsupply.com • E-mail info@edmsupply.com

MOLYBDENUM SPOOLED WIRE

CATALOG NO.	TYPE	METERS	DIA.
C04-0203	MO	5000	0.002
C04-0303	MO	5000	0.003
C04-0403	MO	5000	0.004
C04-0503	MO	4500	0.005
C04-0603	MO	3000	0.006
C04-1002	MO	2000	0.010

Spool size: 5" O.D.; 5/8" bore; 4" tall (3" traverse)

COPPER SPOOLED WIRE

CATALOG NO.	TYPE	SPOOL	DIA.
C05-0660	CO	5.0	0.006
C05-0860	CO	5.0	0.008
C05-1060	CO	5.0	0.010

Physical Properties of Copper and Molybdenum Wire				
Type	Density - gm/cc	Melting PointC	Conductivity	Tensile
Copper	8.9	1083	100%	60,000 PSI
Molybdenum	10.2	2617	34%	70,000 PSI

Please call for price and availability