



EDM Supplies, Inc.®

Electrodes • Tooling • Accessories

800-676-7336 • Fax 562-803-4281

www.edmsupply.com • E-mail info@edmsupply.com

SINKER TOOLING

TABLE OF CONTENTS

| | Page |
|-------------------------------------|-------------|
| Walker Magnetic Chuck..... | 2 |
| Harig Grind-All | 3 |
| Harig Grind-All Accessories | 4 |
| Harig Spin Indexer..... | 5 |
| Harig Spin Indexer Accessories..... | 6 |
| Harig Twin Angle..... | 7 |
| Harig Adjusta-V | 8 |
| Harig Edge-Master | 8 |
| Clear View Radi-Angle | 9 |
| Westhoff Drilling Machine | 10 |
| System 3R Tooling..... | 11 |



EDM Supplies, Inc.®

Electrodes • Tooling • Accessories

800-676-7336 • Fax 562-803-4281

www.edmsupply.com • E-mail info@edmsupply.com

PERMANENT MAGNETIC CHUCK WALKER CERAMAX

Full magnetic surface to all edges

powerful holding over entire chuck surface.

Solid brazed top plate

protects permanent magnetic pack from penetration of coolant; provides stronger, more rigid work surface.

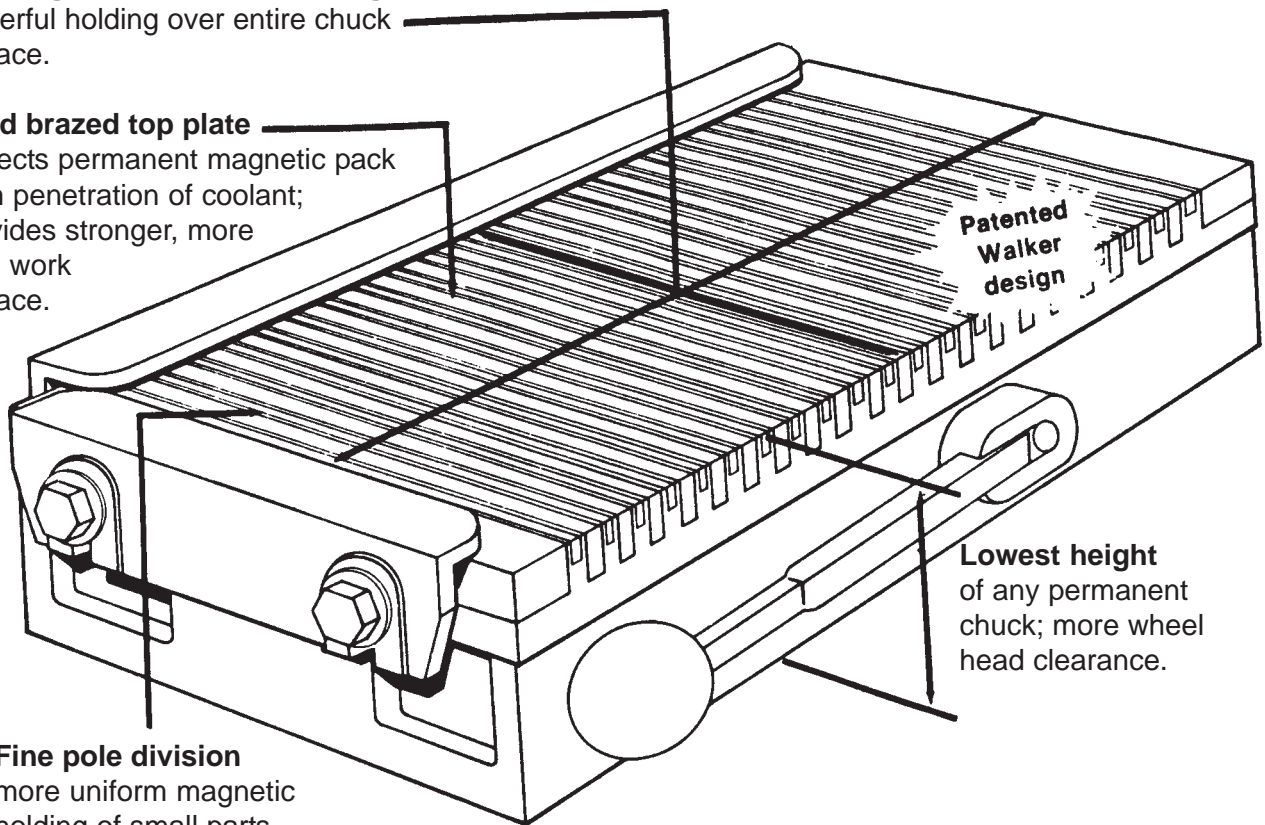

Lowest height
of any permanent
chuck; more wheel
head clearance.

Fine pole division

more uniform magnetic holding of small parts.

| SIZE | HEIGHT INCHES | WEIGHT | CATALOG NUMBER |
|---------------|---------------|--------|----------------|
| 4 x 4 | 2-3/8 | 10 | X75-440 |
| 4 x 8 | 2-3/8 | 20 | X75-480 |
| 5 x 10 | 2-5/8 | 29 | X75-510 |
| 5 x 12 | 2-5/8 | 36 | X75-512 |
| 6 x 10 | 2-5/8 | 36 | X75-610 |
| 6 x 12 | 2-5/8 | 45 | X75-612 |
| 6 x 18 | 2-3/4 | 67 | X75-618 |
| 6-1/2 x 6-1/2 | 2-5/8 | 26 | X75-655 |

Other Magnetic Chucks Available Upon Request

Please call for price and availability.



EDM Supplies, Inc.®

Electrodes • Tooling • Accessories

800-676-7336 • Fax 562-803-4281

www.edmsupply.com • E-mail info@edmsupply.com

HARIG GRIND-ALL NO. 1

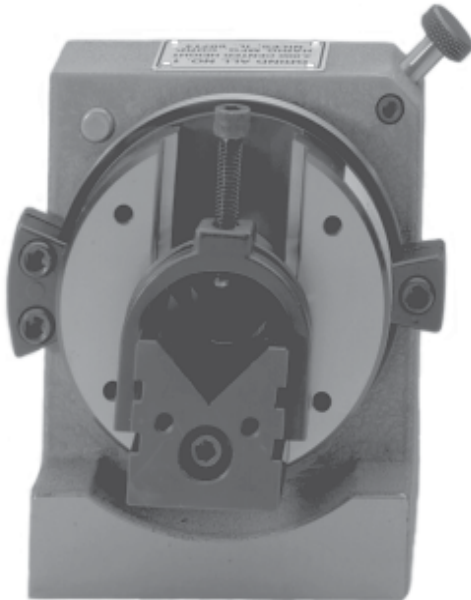

Harig's benchmark precision v-block fixture has improved toolroom productivity since 1951. The original patent holder, copied but never duplicated, is the most accurate indexer of its kind available today. Time tested for high precision work within "tenths," the Grind-All No. 1 sets the standard for grinding punches, core pins, and EDM electrodes. Also used for precision indexing, inspecting, milling, boring, and radius dressing. Complete line of accessories increase applications, and make the Grind-All No. 1 the most versatile v-block fixture ever. Over 20,000 units in action worldwide. When accuracy is of the utmost importance, the Grind-All No. 1 enables you to work with close tolerances. Reliability backed by Harig's trademark service.

Catalog No. X65-100
(includes carrying case)

SPECS

| | |
|--------------------------|----------------|
| V-block capacity | 1-1/4" |
| Center height | 3.000 |
| Through hold | 1-3/16" |
| Graduation | 360 degree |
| 24 division indexing | +/- 10 seconds |
| V-block within | 0.0001 |
| Square and a parallel to | 0.0001 |
| Weight | 12 lbs. |

FEATURES

Hardened and ground tool steel with solid one piece construction

Preloaded ball and race design provides highest accuracy

V-Block adjusting screw allows for quick movement of v-block to +/-0.0001 without tapping

Single screw for fast locking of v-block

360 degrees graduated dial for convenience

24 division index plate with precision index pin locks in every 15 degrees to +/- 10 seconds

2 adjustable stops work with stop pin to set accurate angles between index location

U-Clamp and screw secure piece part in v-block

Removable v-block for accurate faceplate work

Narrow profile maximizes work area under grinding wheel

Mounting holes on base of unit for use with Harig accessories

Lightest fixture of its kind for easy handling

Includes carrying case for protective dust-free storage

Full repair service and replacement parts available

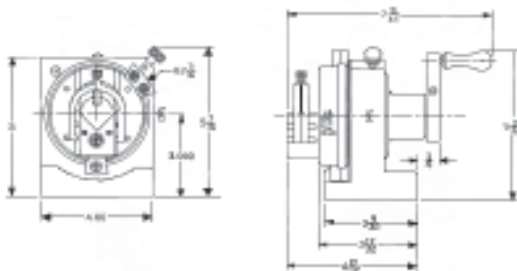

Please call for price and availability.



EDM Supplies, Inc.®

Electrodes • Tooling • Accessories

800-676-7336 • Fax 562-803-4281

www.edmsupply.com • E-mail info@edmsupply.com

HARIG GRIND-ALL NO. 1 ACCESSORIES



SUPER WEE-BLOCKS (065-100)

Catalog No. X65-600

Accurately holds small parts from 0.030" to 9/32"
Set consists of 2 wee-blocks and 2 bridges
Retaining bars: (2) 5/32", (2) 1/8", (1) 1/16"
Hardened and ground to "tenths" accuracy
Includes case

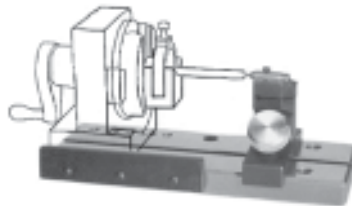

BASE-PLATE & TAIL-STOCK (015-100)

Catalog No. X65-110

4" x 11" with rail
6" capacity between centers
18" base-plate also available
Hardened and ground tool steel



SINE-CHUCK (105-100)

6" x 6" with 2 rails
Permanent magnet
Single angle (5" sine)

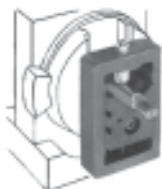

BALL-SEAT PUNCH ADAPTER (10-55)

Accurately locates and clamps ball-seat punch
Nibs available in 1/4", 5/16", 3/8", 1/2"
and 3/4" diameter

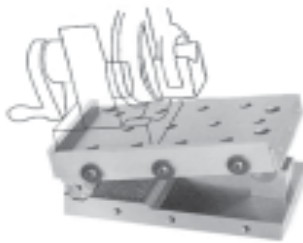

SINE-PLATE (055-100)

Catalog No. X65-115

4" x 6" with rail
Single angle (5" sine)
0.200 minute angle step
Hardened and ground tool steel

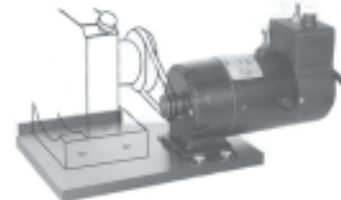

MOTOGROUND (10-70)

For light duty work
Includes motor, base plate, drive belt &
case
Variable speed from 50-550 rpm
1/15 horse power 110v AC motor



LENGTH STOP (10-95)

For multiple piece parts



RECTANGLE-JAWS (075-100)

Catalog No. X65-600

For holding rectangular parts from
0.70 to capacity of v-block
Hardened and ground to "tenths" accuracy
Includes case

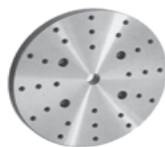

FACE PLATE (10-90)

Catalog No. X65-120

6" diameter
Hardened and ground tool steel

STEADY-REST (135-100)

Catalog No. X85-925

Assists in grinding very small diameters
Magnetic base
Spring loaded plunger

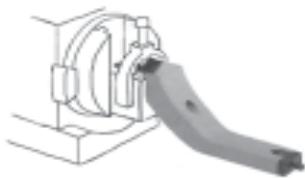

RADIUS DRESSER ARM (10-52)

Catalog No. X65-105

For dressing wheels up to 10" diameter

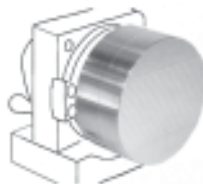

MAGNETIC CHUCK (10-40)

4" diameter
Fine pole permanent magnet

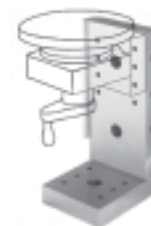

HITE-ANGLE PLATE (085-100)

9-1/2" x 5" x 4" wide
Allows for horizontal use of Harig
fixtures
Includes side rail and mounting holes

Please call for price and availability.



EDM Supplies, Inc.®

Electrodes • Tooling • Accessories

800-676-7336 • Fax 562-803-4281

www.edmsupply.com • E-mail info@edmsupply.com

HARIG SPIN-INDEXER



122-100 Manual
Catalog No. X85-155

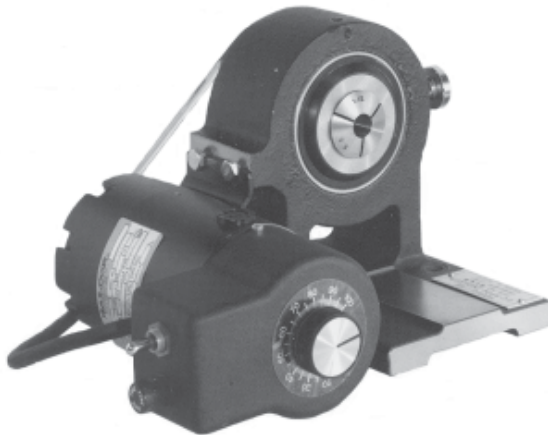

122-100 Motorized
Catalog No. X85-153

SPECS

| | |
|--------------------------|----------------------------|
| Collet | 5C up to 1" |
| Center height | 4-1/8" |
| 24 division indexing | +/- 30 seconds |
| Spindle runout | 0.0001 |
| Spindle parallel to base | 0.0002 in 6" |
| Motor | 1/15 horsepower 110v AC |
| Variable speed | 50-450 rpm |
| Weight | 17 lbs |

Harig's durable 5C collet spin fixture offers "production plus" capabilities and is easily motorized. Suitable for a variety of machining applications, this unit quickly becomes the most useful "spinner" in your toolroom. Variable speed motor attachment can be mounted to Spin-Indexer in forward or rearward position, and makes accurate production work easy. Most complete line of accessories broadens applications. When production work is called for, the Spin-Indexer can be motorized to do the job even more efficiently. Reliability backed by Harig's trademark service.

FEATURES

- Sturdy and dimensionally stable cast iron housing
- Large preloaded ball bearings are durable and accurate - ideal for motorization
- 5C collet holder ground in assembly to under 0.0001 runout
- 24 division index plate with precision index pin locks in every 15 degrees to +/- 30 seconds
- Draw sleeve for quick set-ups of collets and accessories
- Extended base for minimal deflection even with heavier parts
- 1/4" diameter mounting hole on top of housing for diamond dresser
- Mounting holes on base of unit for use with Harig accessories
- Crank handle easily removed for motorized set-up
- Unique design allows for mounting of variable speed motor in forward or rearward position
- Full repair service and replacement parts available

Please call for price and availability.



EDM Supplies, Inc.®

Electrodes • Tooling • Accessories

800-676-7336 • Fax 562-803-4281

www.edmsupply.com • E-mail info@edmsupply.com

HARIG SPIN-INDEXER ACCESSORIES



FACE PLATE (120-50)
5" Diameter
Soft face



STEADY-REST (135-100)
Catalog No. X85-925
Assists in grinding very small diameters
Magnetic base
Spring loaded plunger



DIAMOND NIB (91005)
Inserts into top of fixture
Easily dresses wheels



3-JAW CHUCK (120-60)
1-3/8" maximum opening with straight jaws
3-3/8" maximum opening with step jaws
3/4" thru hole
With 5C adapter shank
Hardened and ground tool steel

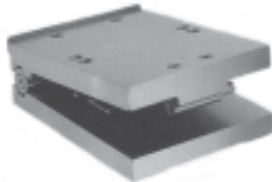

SINE-PLATE (125-100)
Catalog No. X85-915
4-1/2" x 6" with rail
Single angle (5" sine)
0.100 minute angle step
Soft top plate



COLLET STOP (150-100)
Adjustable and threaded
Assists in production work



MANUAL COLLET CLOSER (140-100)
Catalog No. X85-920
Lever action for quick set
ups of collets and accessories



MAGNETIC CHUCK (120-70)
Catalog No. X85-930
4-3/4" diameter, 2-1/4" thick
Standard pole permanent magnet
With adapter shank



ADAPTER PLATE (130-100)
Catalog No. X85-910
3/4" x 4-1/2" x 12"
2" minimum between centers
7-1/2" maximum between centers
1/2" x 2" tail center is adjustable
Includes 5C solid center with drive plate



COLLET STOP SET (145-100)
Adjustable and threaded
4 piece set
Assists in production work



MOTOR ATTACHMENT (120-80)
Motorizes manual Spin-Indexer (120-100)
Includes motor, bracket & drive belt
Mounts in forward or rearward position
Variable speed from 50-450 rpm
1/15 horsepower 110 AC motor



SINE-CHUCK (105-100)
6" x 6" with 2 rails
Permanent magnet
Single angle (5" sine)

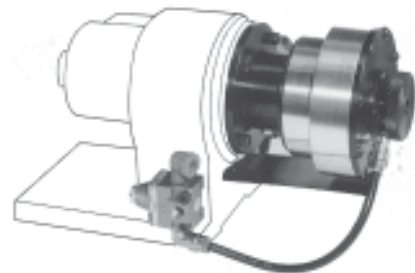

AIR COLLET CLOSER (165-100)
Only for use with motorized Spin-Indexer (120-100)
Mounts directly to back of spindle pulley
Spring set and air released by push of button air valve

Please call for price and availability.



EDM Supplies, Inc.[®]

Electrodes • Tooling • Accessories

800-676-7336 • Fax 562-803-4281

www.edmsupply.com • E-mail info@edmsupply.com

HARIG TWIN-ANGLE

Harig's precision holding fixture mounts electrodes in vertical ram of conventional EDM machine, and serves as a workholder for wire EDM applications. Also can be used for surface grinding applications. Two sizes available with 2-V's each, to accurately hold workpieces within "tenths." When a multipurpose work-holding fixture is needed, look no further than the Harig Twin-Angle. Reliability backed by Harig's trademark service.

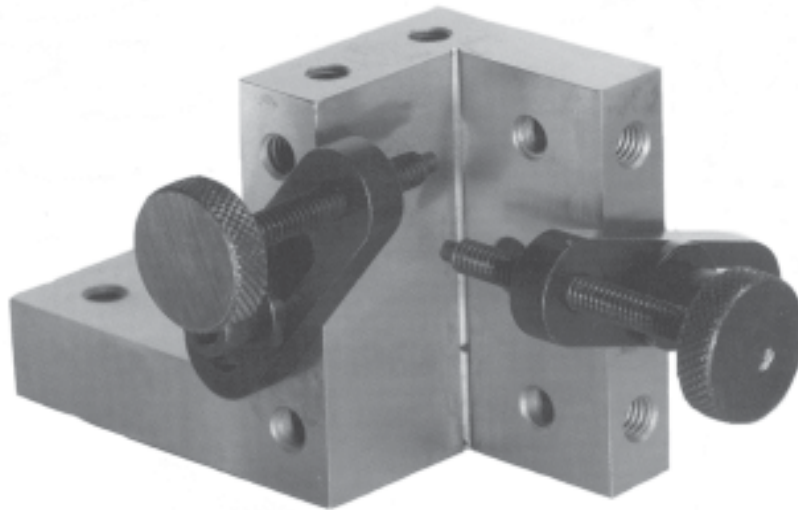

Twin Angle No. 2 (185-100)

Twin Angle No. 1 (045-100)
Catalog No. X65-400

FEATURES

Twin Angle No. 1: 2-5/8" x 2-7/8" and 1-3/8" x 1-7/8"

Twin Angle No 2: 3-1/4" x 2-1/4" and 2-1/4" x 2"

Includes 2 clamps

Optional 3/4" shank or 20 mm shank is available

Hardened and ground to "tenths" accuracy

Please call for price and availability.



EDM Supplies, Inc.®

Electrodes • Tooling • Accessories

800-676-7336 • Fax 562-803-4281

www.edmsupply.com • E-mail info@edmsupply.com

HARIG ADJUSTA-V

Harig's v-block holder mounts to conventional EDM machines and centers electrodes accurately. Can be used as a v-block attachment with any collet fixture. Versatile unit makes centering workpiece with odd or dimensionally varied shank diameters quick and easy. Holder is more rigid than collets and allows operator to work with "tenths". When an electrode needs to be secured in a v-block configuration, there is an Adjusta-V to fit every application. Reliability backed by Harig's trademark service.

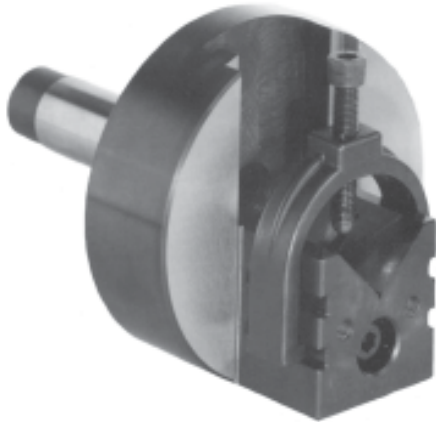

FEATURES

- 1-1/4" v-block capacity
- Positioning accuracy to 0.001"
- 3/4" adjustment to either side of center
- Shank has center hole for holding longer electrodes
- Single screw for fast locking of v-block
- Hardened and ground tool steel
- Full repair service and replacement parts available
- 190-100 with 1" diameter shank
- 101-100 with 20mm diameter shank
- 192-100 with 30mm taper shank
- 193-100 with 40mm taper shank

HARIG EDGE-MASTER

Harig's precision mounting table permits a variety of machining applications. Ideal for light drilling, milling, boring, jig-grinding and EDM workholding. Having workpiece overhang edges can extend 6" x 12" capacity. The Edge-Master allows a flush cup to be mounted beneath the workpiece for EDM reverse flush set-ups. When "tenths" accuracy is needed on an all-purpose mounting table, look no further than the Edge-Master. Reliability backed by Harig's trademark service.

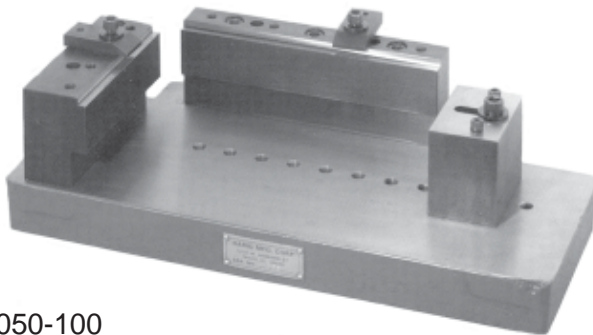

050-100

FEATURES

- 6" x 12" capacity can be expanded with workpiece overhang
- 2 rails on vertical mounting blocks provide constant x/y coordinates
- A support block may be used for precise flatness and quick set ups
- Hardened and ground to "tenths" accuracy
- Ideal for multiple parts
- Mounting holes provide flexibility
- 3 Flush Cup sizes available 1", 2", 3"
- Full repair service and replacement parts available

Please call for price and availability.



EDM Supplies, Inc.®

Electrodes • Tooling • Accessories

800-676-7336 • Fax 562-803-4281

www.edmsupply.com • E-mail info@edmsupply.com

CLEAR VIEW RADI-ANGLE FORM WHEEL DRESSER ACCURACY TO .0001"

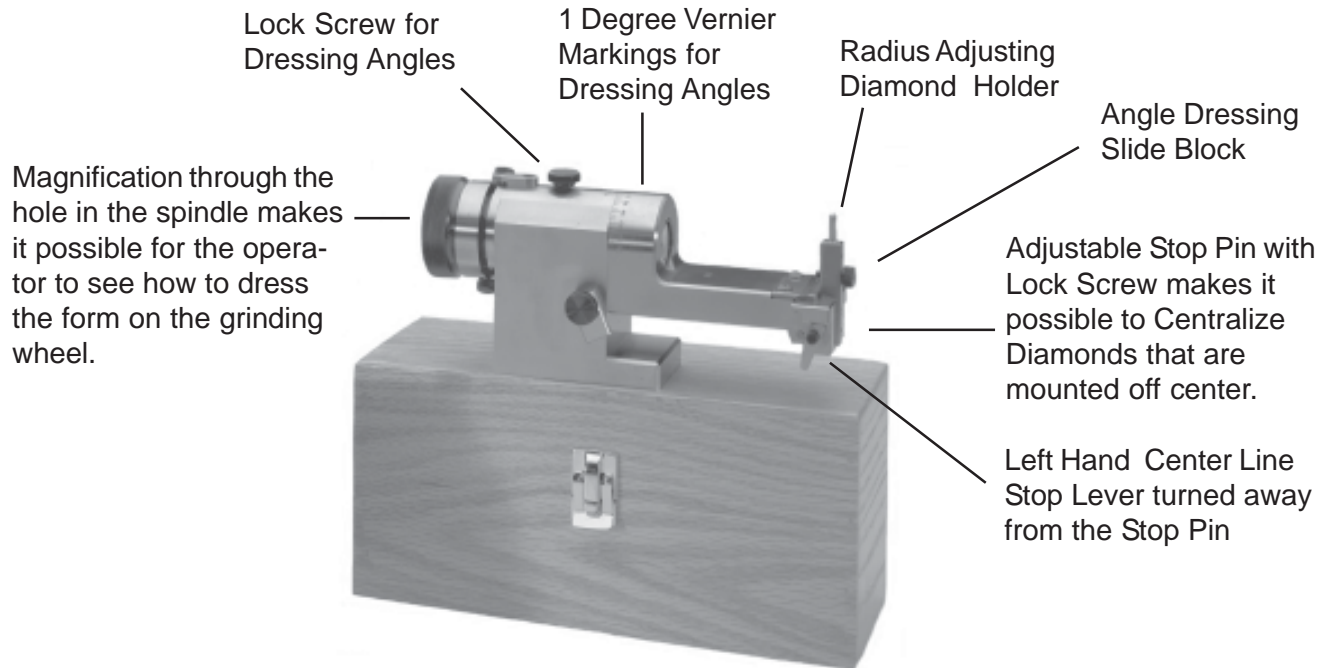

By "sighting" the diamond point through the lens in the hole of the spindle, radii and angles can easily be made perfectly tangent visually, even with the lowest cost of diamonds. Likewise, radii can be blended together with the most unbelievable accuracy. There is no guess work!

Specifications

- Height - 4"
- Length - 8-1/4"
- 180° Swing Arm, Graduated in one degree spacings
- Maximum size grinding wheel 8" diameter
- Maximum outside radius (on wheel) approximately 5/8"
- Maximum inside radius (on wheel) approximately 1"
- Spindle 1" diameter O.D. hardened, ground and lapped. Hand fitted to insure perfect bearing.

CATALOG NO. X70-200

Inside: Dresser, Carrying Case, 1/8" Diamond and Holder

Shipping Weight: 11 lbs.

Please call for price and availability.



EDM Supplies, Inc.®

Electrodes • Tooling • Accessories

800-676-7336 • Fax 562-803-4281

www.edmsupply.com • E-mail info@edmsupply.com

WESTHOFF DRILLING MACHINE

Unique horizontal drilling machine for putting coolant holes in graphite or metallic electrodes.

| DESCRIPTION | PRICE | CATALOG NO. |
|-----------------------------------|-------|-------------|
| Model 100-1 (8 1/2" table travel) | *call | X35-001 |

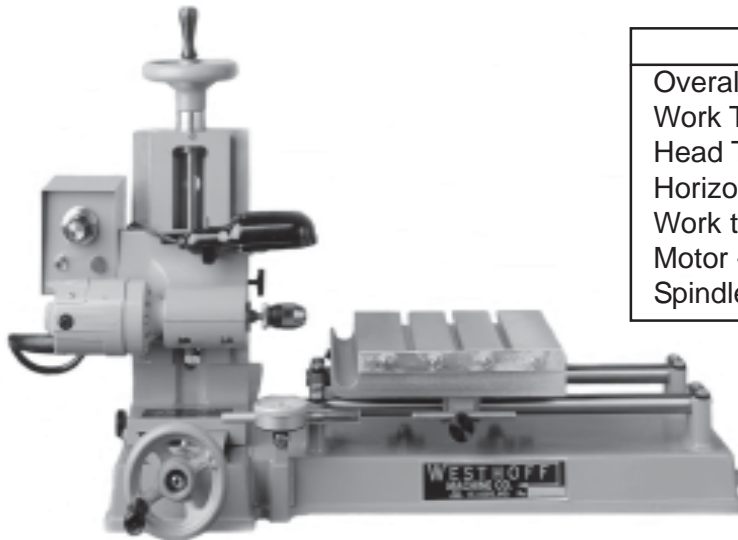

| SPECIFICATIONS |
|---|
| Overall Size - 18" H x 24" W x 26" L |
| Work Table - 8-1/2" x 8-1/2" with 8-1/2" travel |
| Head Travel - 4-1/2" vertical |
| Horizontal travel - 12" |
| Work table load - 30 lbs. |
| Motor - 1/10 HP, 155 v |
| Spindle speed - 0 to 15,000 RPM |

WESTHOFF MICRO FLUSH DRILLS

| DIA. | Flute Length | O.A. Length | CATALOG NO. |
|------|--------------|-------------|-------------|
| .010 | 1/4 | 2 | X35-102 |
| | | 4 | X35-104 |
| .015 | 3/8 | 2 | X35-152 |
| | | 4 | X35-154 |
| | | 6 | X35-156 |
| .020 | 1/2 | 2 | X35-202 |
| | | 4 | X35-204 |
| | | 6 | X35-206 |
| .025 | 1/2 | 2 | X35-252 |
| | | 4 | X35-254 |
| | | 6 | X35-256 |

| DIA. | Flute Length | O.A. Length | CATALOG NO. |
|------|--------------|-------------|-------------|
| .030 | 1/2 | 2 | X35-302 |
| | | 4 | X35-304 |
| | | 6 | X35-306 |
| .035 | 1/2 | 2 | X35-352 |
| | | 4 | X35-354 |
| | | 6 | X35-356 |
| .040 | 1/2 | 2 | X35-402 |
| | | 4 | X35-404 |
| | | 6 | X35-406 |
| .050 | 1/2 | 4 | X35-504 |
| | | 6 | X35-506 |
| .060 | 1/2 | 4 | X35-604 |
| | | 6 | X35-606 |

Please call for price and availability.



EDM Supplies, Inc.®

Electrodes • Tooling • Accessories

800-676-7336 • Fax 562-803-4281

www.edmsupply.com • E-mail info@edmsupply.com

SYSTEM 3R TOOLING

Provides the edge you need to achieve peak efficiency.

3R Macro is a universal reference system that offers endless possibilities in reducing or eliminating set-up times. Electrodes mounted to Macro holders maintain precise references as they move throughout the fabrication processes and into EDMing.



The **MacroJunior** system is designed to carry the accuracy and stability of the Macro design to the smaller-electrode applications. MacroJunior chucks are provided with the precision reference tongues, allowing for very economical electrode holders.



3R MacroCombi is the best of both: Macro for unbeaten accuracy and stability even for the largest electrodes; MacroJunior for economy and stability for the most common electrode sizes. The locking mechanism is entirely separate from both reference systems.

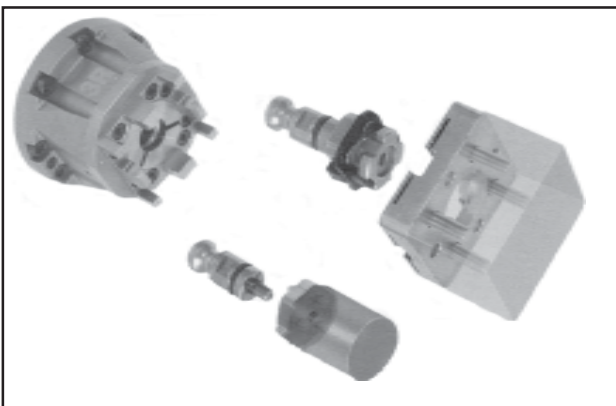

3R Mini The time-tested classic, 3R's 20mm shank is the most widely used electrode holder in the world. An extensive and time-tested system of hydraulic chucks and inexpensive holders that combine to provide accuracy and flexibility.

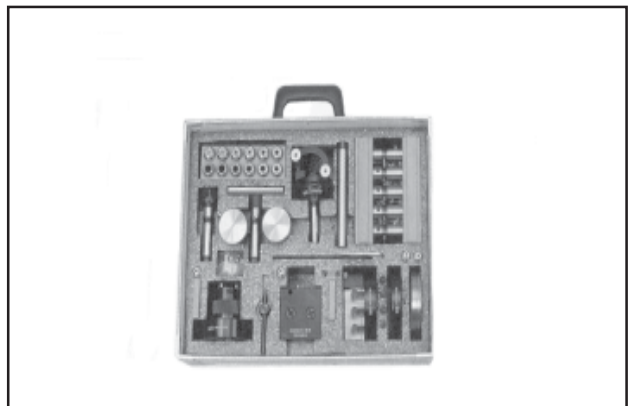

Please call for price and availability.